

# Cast Steel (WCB) 'Y' type Strainer

## ND-40 DESIGN

### TECHNICAL DATA

Manufacturing Std. : As per Manufacturing.

Testing & Insp. Std. : API 598.

Face to Face : As per ND-40.

End Connection : Flanged as per BS 10  
Table (F) OR ASA 150#



SR. NO.	NOMENCLATURE	MATERIAL
1	BODY	C.S. (ASTM A 216 Gr. WCB)
2	STUD & NUT	M.S. IS - 1367.
3	MESH	SS 304.
4	COVER	M.S.
5	GASKET	CAF / SPIRAL.

SIZE		L	T	K	D	N	J	R
INCH	M.M.	Fl TO Fl	(F.T.)	(PCD)	O.D.	No of Hole	Hole Dia	R/F
1"	25	160	16	80	107	04	15	51
1.1/2"	40	200	19	98	127	04	15	73
2"	50	230	20	121	152	04	19	92
2.1/2"	65	290	20	140	178	04	19	105
3"	80	310	21	152	190	04	19	127
4"	100	350	24	190	229	08	19	157
5"	125	400	24	216	254	08	22	186
6"	150	480	24	241	279	08	22	216
8"	200	600	30	298	343	08	22	270

SERVICE RATING & TEST PRESSURE				
CLASS	WORKING PRESSURE (MAX)	TEMPERATURE (MAX)	HYD. TEST PRESS.	
			BODY	SEAT
ND-40	10KG/CM2	300 DEG. C.	40KG/CM2	----

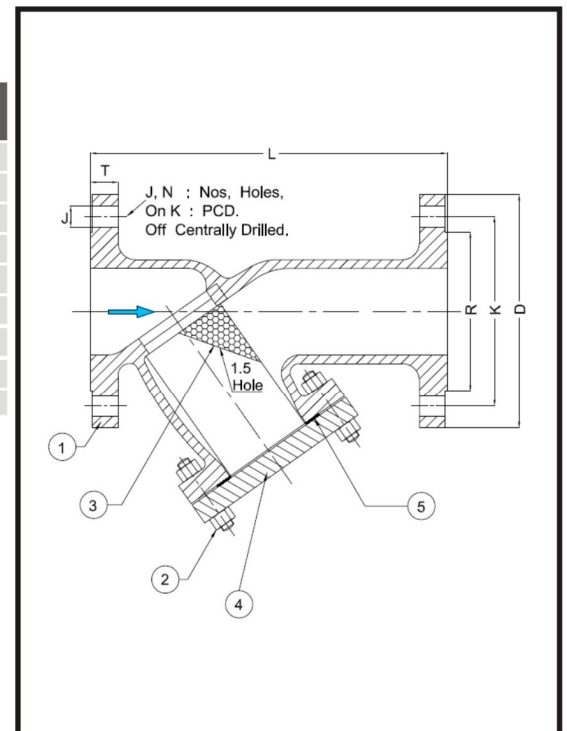

\*All dimensions are in M.M.

Manufactured by :- VALSON VALVES MFG. CO. - AHMEDABAD. (GUJ.)

Visit us : [www.valsonvalves.com](http://www.valsonvalves.com)